



DATA SPECIFICATION FOR THE HIGH INTERCEPT LOW NOISE AMPLIFIER

MODEL NUMBER:

HILNA™ V1

NuWaves Engineering

SUPERIOR ENGINEERING DESIGN SERVICES

NuWaves' HILNA™ family of amplifiers is designed to achieve extremely low noise and high third-order intercept point along with high gain. These characteristics are maintained across a wide band, from 50 MHz to 1 GHz.

NuWaves Engineering
Research and Technology Center
122 Edison Drive
Middletown, Ohio 45044-3269

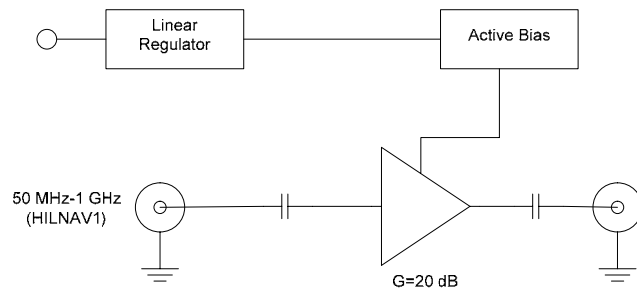

Phone: 513-360-0800
Fax: 513-360-0888
E-mail: product.sales@nuwaves-ltd.com
<http://www.nuwaves-ltd.com>

1. PRODUCT OVERVIEW

1.1 Product Highlights

- High Performance - Noise, Gain, Intercept, Dynamic Range: Unprecedented unique combination of extremely low noise (0.8 db), High Gain (20 dB), High Intercept (+32 dBm), and wide frequency range (V1 - 50 MHz to 1 GHz).
- Robust Power Supply: Operates over a very broad range of power supply voltages (5-30 VDC), easily allowing the HILNA™ to be integrated into systems without regard to power supply precision. Included with each amplifier is a mating power connector with cable attached.
- Enclosure: The HILNA™ Amplifier is housed in a sleek black anodized extruded aluminum enclosure with optional mounting flanges.
- Completely Characterized: The HILNA™ family of amplifiers has been completely characterized over temperature, voltage, and frequency. The amplifiers are robust offering significant value for the OEM user or the Systems Integrator.
- Low Cost: HILNA™ amplifiers are competitively priced. The unique combination of linearity, low noise, and broadband operation meet the demanding needs of state-of-the-art designs delivering high value for little cost.
- User Friendly: Reverse voltage protection and regulator thermal shutdown provide defenses against user interface issues.
- High Reliability: NuWaves' selections of conservatively rated components provide high reliability delivering high MTBF numbers. Each HILNA™ is quality inspected to IPC-A-610 Class III standards.

1.2 Product Description

Product	HILNA™
Functional Description	NuWaves' HILNA™ family of amplifiers is designed to achieve extremely low noise, high linearity, wideband operation while delivering high RF gain. Other characteristics include reverse voltage protection and an internal regulator and active bias.
Applications	IF or RF Buffer Amplifier ▪ Overcome Systematic RF Losses ▪ Increase Antenna Signal Levels ▪ Military Radios ▪ RF Wideband Front-Ends ▪ RF PreAmp ▪ TV ▪ Final Stage Amplifier for Low-Level Repeaters ▪ Long Cable Runs to Antenna ▪ Ultra Low Noise Applications ▪ LNA for Cellular Base Station ▪ High Linearity Systems ▪ General Purpose Amplification ▪ High Performance Receivers ▪ Amplification of Extremely Low-Level RF ▪ High Power Drive Signals for Increased Dynamic Range ▪ High Reliability RF Amplifier Applications ▪ Base Station Applications ▪ VHF/UHF Amplification ▪ Final PA for Low-Power Applications ▪ GPS LNA ▪ Low-Noise Transmit Driver ▪ Cable Modem ▪ Broadband Low Noise Gain Block ▪ Fixed Wireless ▪ Mobile Infrastructure
Users	Engineering and Scientific Laboratories ▪ Test and Measurement Facilities ▪ OEMs of RF High End Systems ▪ Research Laboratories ▪ Communications Engineering Firms ▪ Cable TV System Engineers ▪ RF System Integrators ▪ Test Ranges ▪ Universities ▪ Antenna Design Facilities ▪ Field Service Technicians ▪ Aerospace and Defense Systems ▪ Radio and TV Engineers ▪ Amateur Radio ▪ Scientific and Consulting Agencies ▪ Radio and Wireless Communication Services ▪ Precision Equipment Repair Organizations ▪ Professional and Technical Service Institutions
Mounting Technology	SMT

1.3 Product Variants

NuWaves offers several variants of the HILNA™ line-up, covering 50 MHz to 5 GHz within three separate modules. The different frequency variants and their availability are:

- V1 – 50 MHz to 1 GHz (FULL PRODUCTION)
- V2 – 1 GHz to 3 GHz (PROTOTYPE PHASE)
- V3 – 3 GHz to 5 GHz (PROTOTYPE PHASE)



HILNA™ V1 Module Assembly
(shown with optional mounting flanges)

1.4 Part Number Ordering Information

Part Number	Description
HILNA™ V1	50MHz – 1GHz High Intercept Low Noise Amplifier, Extruded Aluminum Enclosure
HILNA™ V2	1GHz – 3GHz High Intercept Low Noise Amplifier, Extruded Aluminum Enclosure
HILNA™ V3	3GHz – 5GHz High Intercept Low Noise Amplifier, Extruded Aluminum Enclosure

2. INSTALLATION, CONNECTING, AND USING THE HILNA™ AMPLIFIER

HILNA™ amplifiers have been designed to be highly reliable under the specified operating conditions. The following installation and hook-up guide lines should be followed to prevent damage to the RF module.

The HILNA™ amplifier contains components that are sensitive to Electro-Static Discharge (ESD). The OEM variant should be installed in an ESD safe environment. The use of wrist strap, mats, and ground straps should be adhered to during the installation process.



CABLING: The HILNA™ V1 unit is equipped with high performance RF connectors. Gold plated SMA-type receptacles are used because they perform very well across the usable frequency range of the unit. For optimal performance, a high quality 50Ω coaxial cable with SMA-type plugs should be used to connect the unit to an antenna and also to the receiver. The best result will be obtained when the unit is installed as close as possible to the antenna.

CAUTION: Due to the wideband nature of the unit, installation should not be attempted on a tower with transmit antennas.

If cables with the SMA-type connectors are not available, high quality adaptors are available for most coaxial connector types.

POWER SUPPLY: The HILNA™ V1 contains an internal linear voltage regulator. This regulator protects the circuitry from voltage variations at the input and allows for the wide operating voltage. The power connector is an industry standard 2.1mm circular connector. The only restrictions on the power source for the unit are:

- Capable of sourcing 100mA of current
- Capable of sourcing +5VDC to +30VDC

Car batteries (through a cigarette lighter adaptor), laboratory DC power supplies, or wall transformers are suitable power sources as long as the superimposed ripple is low in amplitude.

CONNECTIONS: Making the connection from the HILNA™ V1 to the receiver is easily accomplished. Note: Do not apply RF to the unit until after all cable connections are made and power has been applied.

One 50Ω coaxial cable is used to connect the antenna to the connector labeled "RF IN." A second 50Ω coaxial cable is used to connect the receiver input to the "RF OUT" connector on the unit. Finally, power is applied to the unit by first plugging the power cable sent with the unit into the 5-30VDC connector on the unit. Next connect the red lead to the + side of the power supply and connect the black lead to the – side of the power supply. Apply RF to the input cable assembly. Powering down the unit is done by reversing this procedure.

Connection Summary:

- Connect the RF Output to a good load. The characteristic impedance is 50Ω.
- Apply 5-30 VDC (12 Typical) at the power connector.
- Connect an RF source to the RF Input connector.



Excess drive levels at the input to the amplifier can permanently damage the HILNA™ amplifier. Under no circumstance should the RF Input level exceed 20 mW (+13 dBm) of RF Power.

ENVIRONMENT: The HILNA™ V1 unit is rated for operation from -20°C to +70°C. The enclosure is NOT watertight so the unit must be kept dry. It is recommended that the unit be installed in a well-ventilated area or mounted to a heat sink if the input voltage exceeds +15VDC. The unit will run warmer as the input voltage increases.

SUMMARY: The HILNA™ V1 is an easy way to increase the effective range of any receiver and/or is the perfect RF gain device for operating in the range of 50MHz to 1GHz. By following this installation guide, a unit can be successfully installed in most scenarios.

3. ELECTRICAL DATA

3.1 Absolute Maximum Ratings

Operating Voltage	30 V
RF P _{in}	20 mW
Operating Temperature	-20° C ... + 70° C
Storage Temperature	-20° C ... + 70° C

3.2 DC Characteristics

		min	typ	max
Operating Voltage	V	5	12	30
Current Consumption	mA	66	70	78

3.3 RF Characteristics

		HILNA™ V1			HILNA™ V2			HILNA™ V3		
		min	typ	max	min	typ	max	min	typ	max
Frequency Range	MHz	50		1000	1000		3000	3000		5000
Gain	dB	15	20	23						
Noise Figure	dB	.6	.8	2.0						
OIP3	dBm	30	32	34						
P1dB	dBm	16	18	19						
VSWR In		1.1	1.3	1.6						
VSWR Out		1.1	1.5	2.3						
Reverse Isolation	dB	25	27	30						

Measurement Conditions:

Z₀ = 50 Ω at input and output

P_{in} = -10 dBm

T_{amb} = 25° C

OIP₃:

P_{out} = 2 x 0 dBm; Δf = 300 KHz

3.4 HILNA™ V1 Graphs

Gain vs. Frequency

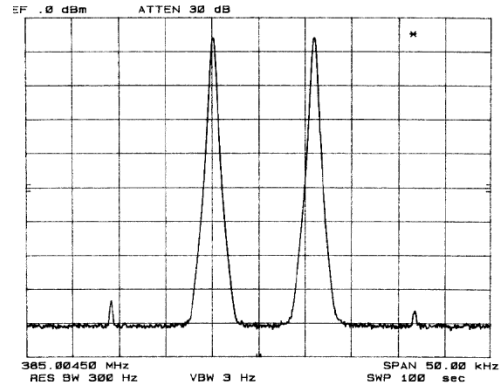
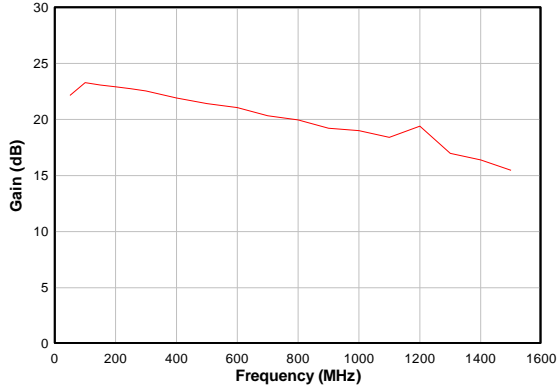

Noise Figure vs. Frequency

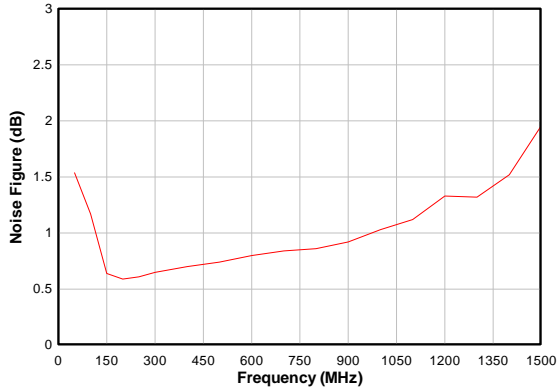

Reverse Isolation vs. Frequency

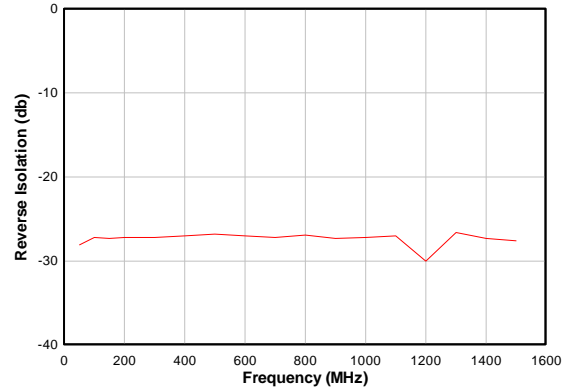

**Gain vs. Temperature
(@ 150 MHz)**

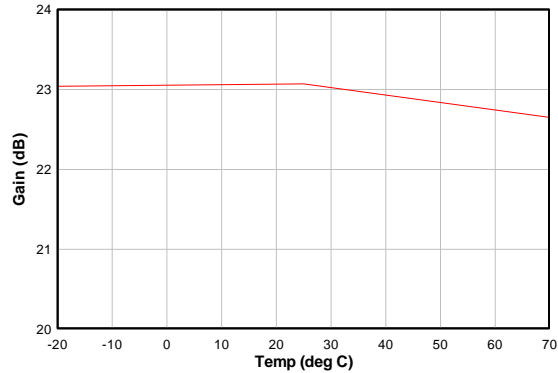

VSWR In/Out

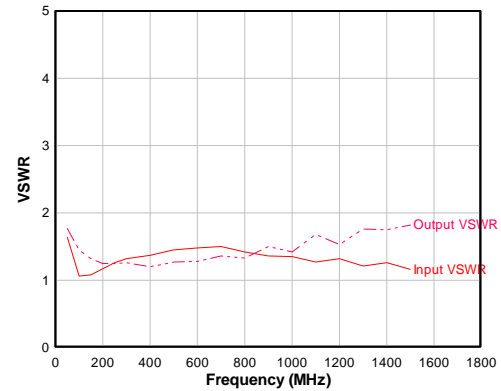

4. MECHANICAL OUTLINE

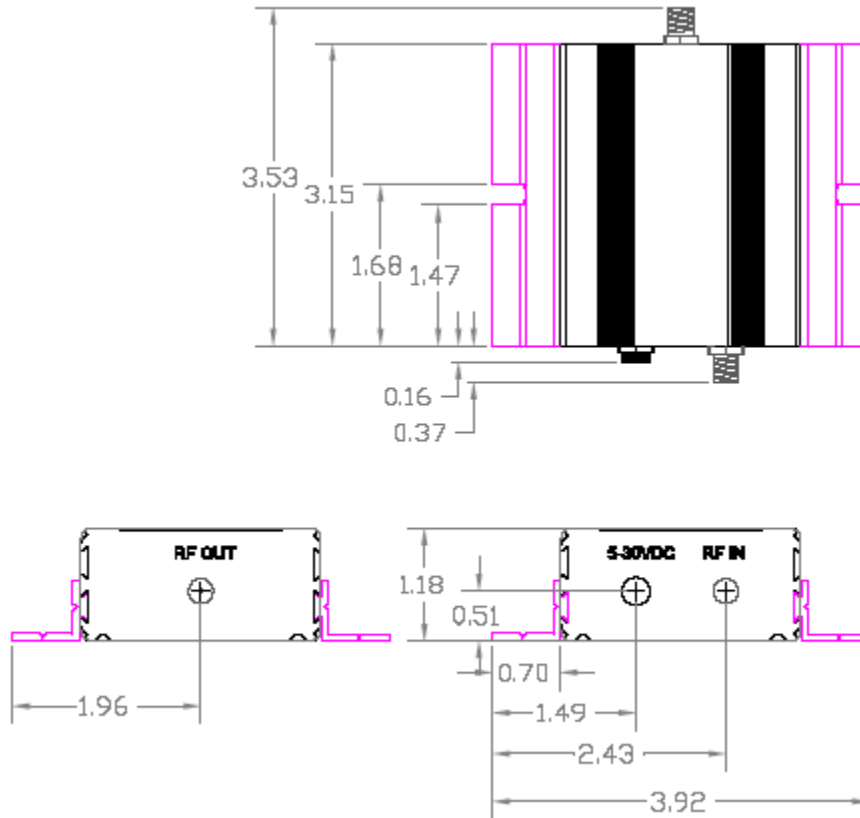

RF Bulkhead Connector Type = SMA (Female)
 RF Input and Output Mating Connector: SMA (Male)

DC Power Connector Type = 2.1mm Circular
 Bulkhead Connector: Switchcraft 772A
 Mating Connector: Switchcraft S760

Maximum Outline Dimensions (without mounting flanges)	
Length	3.15 in
Width	2.50 in
Height	1.18 in
Weight	4.2 oz.

5. GETTING ASSISTANCE – PRODUCT SUPPORT

NuWaves is proud of its products, and getting assistance in setting up your HILNA™ amplifier is easy.

Sales and Technical Solutions Engineering:

Mr. Kevin Harrison
(513) 360-0800 Ext. 313
FAX: (513) 360-0888
Email: kharrison@nuwaves-ltd.com

Mr. Thoeun Huon
(513) 360-0800 Ext. 110
FAX: (513) 360-0888
Email: thuon@nuwaves-ltd.com

NuWaves Home Page: <http://nuwaves-ltd.com>

Standard Product Warranty: http://nuwaves-ltd.com/pdf/Standard_Warranty.pdf

6. GENERAL INFORMATION

Copyright © 2005 – 2009 NuWaves Ltd. All rights reserved. The information contained in this manual is copyright protected. NuWaves reserves the right to make periodic modifications and product improvements to the HILNA™ product line and the associated documentation.